

M SERIES TANDEM FILTER CART



Two Filter Carts in One!

When you need multiple filter carts but, don't have the budget or the space, look no further than the TH-M Tandem cart. This cart is two filter carts in one which allows you to filter two different oil types using a single cart - saving time and money. Extremely mobile, this filter cart has all the power needed for filtering oil viscosities up to 600cSt (ISO VG 680) at 100F within ambient temperature ranges of -15F to 150F. All Y2K products are 100% customizable upon request.

Typical Applications

- Filtering contaminated systems
- Flushing new or repaired systems
- Pre-filtering new oil
- Transferring oils
- Topping off reservoirs
- Collecting oil samples for analysis
- Dispensing new oil

Y2K
Y2K

FLUID POWER



3620 North Lewis Ave., Sioux Falls, SD 57104 | 888.925.8882 | y2kfluidpower.com

A DIVISION OF DAKOTA FLUID POWER, INC.

M SERIES TANDEM FILTER CART

Don't see the options you need?
Contact Y2K at 1(888) 925-8882
or sales@y2kfluidpower.com

Performance:

For filtering mineral and synthetic based oils (hydraulic oils, gear oils and turbine oils) with a maximum operating viscosity range of ISO VG 680 (3000ssu/648cSt) at 100 °F within ambient temperature ranges of -15 °F to 150 °F.

Standard Features:

Materials:

- Frame: Carbon Steel
- Paint: Multiple color options available
- Motor: 1HP, 115vac, 60Hz or Pneumatic
- Filter Heads: Low pressure, aluminum heads
- Pump: Aluminum gear pump. Available in 2, 5 and 10 GPM
- Connections: Various quick connect options available
- Hoses: 7ft. Clear PVC, steel reinforced hose or hydraulic hose
- Power Switch: Sealed On/Off Power Switch

Filter Indicators:

- Pop up indicator triggers at 50psid when elements need to be changed.

Pump Relief:

- Opens at 150psi

Weight:

- Approx. 200lbs (will vary depending on options)

Dimensions:

- Approx. 23"L x 22"W x 52"H

Replacement Elements:

Part Number	BETA Rating	Desired Cleanliness Level (ISO Code)
P1068	$\beta_{3(c)}=1000$	14/12/9 - 13/11/8
P1069	$\beta_{6(c)}=1000$	17/15/12 - 14/12/9
P1070	$\beta_{10(c)}=1000$	18/16/13 - 17/15/12
P1071	$\beta_{25(c)}=1000$	21/19/16 - 20/18/15
P1072WR	Water Removal	

All M Series elements measure 5" x 10".

Components:

Item Number	Description	Qty.
1	Frame	1
2	Motor	1
3	Pump	1
4	Filter Head	4
5	Filter Element	4
6	Filter Indicator	4
7	Switch On/Off	1
8	Cord Wrap Area	1

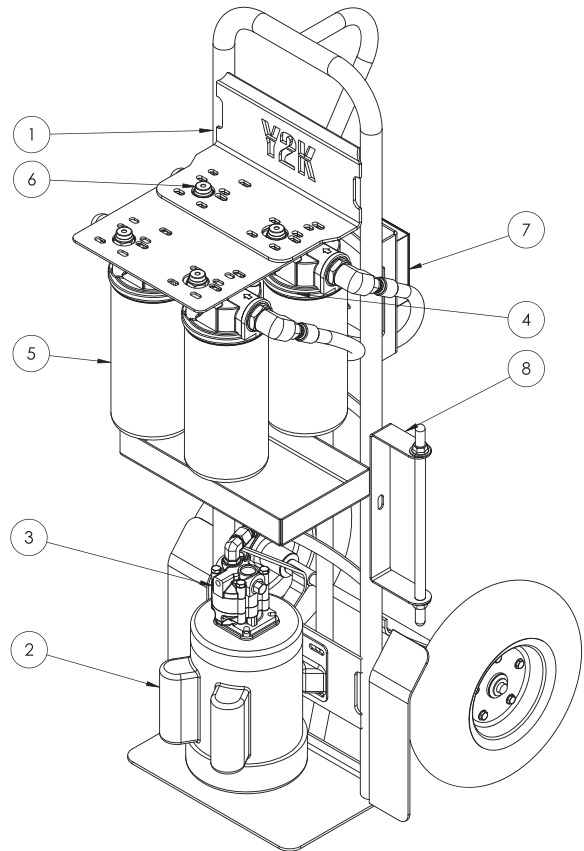

Y2K
FLUID POWER

FLUID POWER



3620 North Lewis Ave., Sioux Falls, SD 57104 | 888.925.8882 | y2kfluidpower.com

A DIVISION OF DAKOTA FLUID POWER, INC.